

SPE10S60F-A

主要参数 MAIN CHARACTERISTICS

600V/10A 三相全桥智能功率模块	
V_{CES}	600V
$\pm I_C$	10A
$\pm I_{CP}$	20A

用途

- 洗衣机
- 风机

APPLICATIONS

- Washing machine
- Fan

产品特性

- 下臂 IGBT 发射极输出，内置自举二极管。
- 600V/10A 三相逆变器，内置低损耗沟道栅-场截止型 IGBT。
- IGBT 驱动：增强型输入滤波，上下臂互锁，高速 600V 电平转换，电源欠压保护，短路（过流）保护。
- 故障信号：对应于短路（过流）和 VP1 电源欠压故障。
- 输入接口：兼容 3.3V & 5V 输入信号，高电平有效。
- 温度检测：NTC 检测输出和 IC 内部检测输出。

FEATURES

- Lower arm IGBT emitter output, built-in bootstrap diode.
- 600V/10A three-phase inverter with built-in low-loss trench gate-field stop IGBT.
- IGBT drive: enhanced input filtering, interlocking of upper and lower arms, high-speed 600V level conversion, power supply undervoltage protection, short circuit (overcurrent) protection.
- Fault signal: corresponds to short circuit (overcurrent) and VP1 power undervoltage fault.
- Input interface: compatible with 3.3V&5V input signals, high level effective.
- Temperature detection: NTC detection output and IC internal detection output.

封装 Package

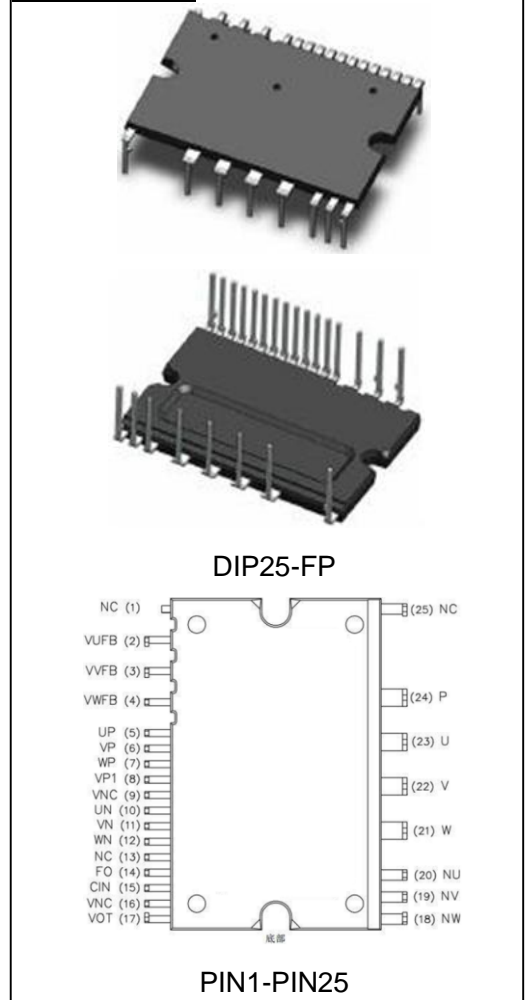

订货信息 ORDER MESSAGE

订货料号 Order number	产品信息 Product information					
	无卤-条管 Halogen-Free-Tube	无卤-编带 Halogen-Free-Reel	印记 Marking	封装 Package	温度输出 Temperature output	管脚长度 Pin Length
2A01-0525-16	SPE10S60F-A	N/A	SPE10S60F-A	DIP25-FP	NTC	常规 normal



SPE10S60F-A

2A01-0526-16	SPE10S60F-A	N/A	SPE10S60F-A	DIP25-FP	IC 集成 IC integration	常规 normal
2A01-0640-16	SPE10S60F-A	N/A	SPE10S60F-A	DIP25-FP	IC 集成 IC integration	短脚 short

模块示意图 **Module diagram**



图 1：模块内部电路示意图

Fig 1: Internal circuit

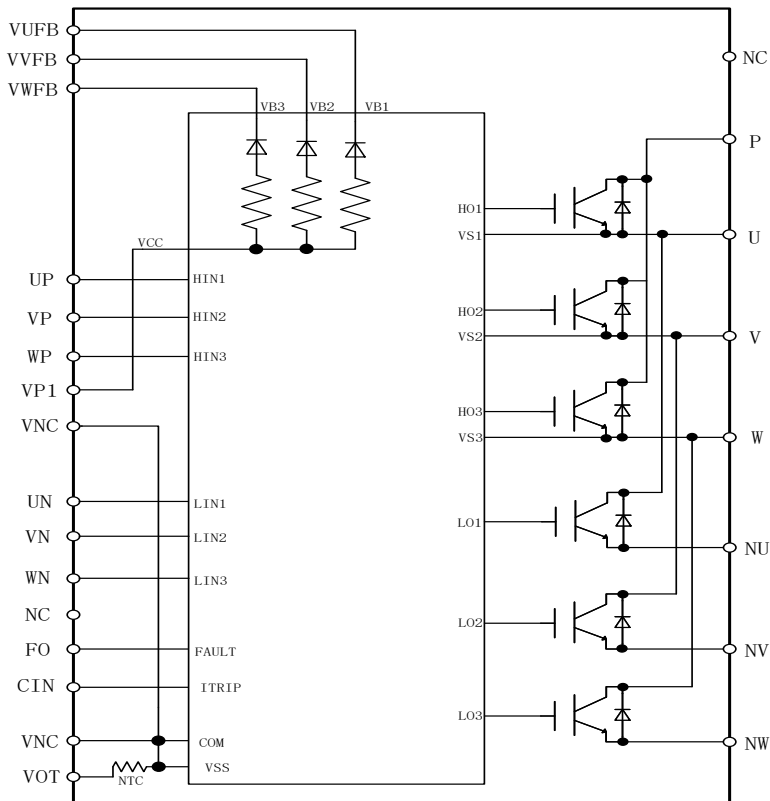

图 2：模块引脚分布示意图

Fig 2: Distribution of pin

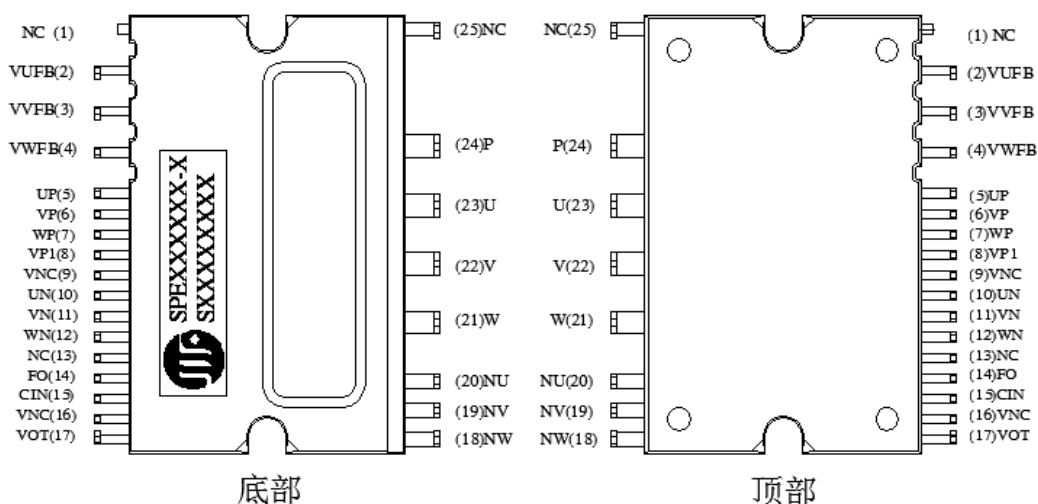

管脚编号 Pin Number	管脚名称 Pin Names	管脚描述 Pin Description
1	NC	无连接 connectionless
2	VUFB	U 相上臂驱动电源端子 U-phase upper arm drive power terminal
3	VVFB	V 相上臂驱动电源端子 V phase upper arm drive power terminal
4	VWFB	W 相上臂驱动电源端子 W phase upper arm drive power terminal
5	UP	U 相上臂控制信号输入端子 U-phase upper arm control signal input terminal
6	VP	V 相上臂控制信号输入端子 V phase upper arm control signal input terminal
7	WP	W 相上臂控制信号输入端子 W phase upper arm control signal input terminal
8	VP1	控制电源端子 Control power terminal
9	VNC	控制电源 GND 端子 Control power GND terminal
10	UN	U 相下臂控制信号输入端子 U-phase lower arm control signal input terminal
11	VN	V 相下臂控制信号输入端子 V phase lower arm control signal input terminal
12	WN	W 相下臂控制信号输入端子 W phase lower arm control signal input terminal
13	NC	无连接 connectionless
14	FO	故障输出端子 Fault output terminal
15	CIN	短路保护触发电压检测端子 Short circuit protection trigger voltage detection terminal
16	VNC	控制电源 GND 端子 Control power GND terminal
17	VOT	温度检测输出端子 Temperature detection output terminal
18	NW	W 相下臂 IGBT 发射极端子 W phase lower arm IGBT emitter terminal
19	NV	V 相下臂 IGBT 发射极端子 V phase lower arm IGBT emitter terminal
20	NU	U 相下臂 IGBT 发射极端子 U phase lower arm IGBT emitter terminal
21	W	W 相输出端子 W phase output terminal
22	V	V 相输出端子 V phase output terminal
23	U	U 相输出端子 U phase output terminal
24	P	逆变器直流输入端子 Dc input terminal of inverter
25	NC	无连接 connectionless

图 3: 模块引脚功能定义表

Fig 3: Pin function

最大额定值 (T_j= 25°C,除非特别说明)Absolute Maximum Ratings (T_j= 25°C, Unless otherwise Specified)

逆变部分 Inverter Part

记号 Mark	项目 Project	条件 Condition	额定值 Ratings	单位 Units
V _{CC}	电源电压 supply voltage	应用于 P- NU, NV, NW 之间 It applies between p-nu, NV, and NW	450	V
V _{CC(Surge)}	电源电压 (含浪涌) Supply voltage (including surge)	应用于 P- NU, NV, NW 之间 It applies between p-nu, NV, and NW	500	V
V _{CES}	集电极-发射极间电压 Collector to emitter voltage	/	600	V
± I _C	集电极电流 Collector current	T _C = 25°C (T _C 测试方法见图 4) TC = 25°C (see Figure 4 for T _C test method)	10	A
± I _{CP}	集电极电流 (峰值) Collector current (peak)	T _C = 25°C, 脉冲宽度小于 1ms TC = 25°C, pulse width is less than 1ms	20	A
P _C	集电极功耗 Collector power consumption	T _C = 25°C, 单晶片 TC = 25°C, single chip	24	W
T _j	结温 Junction temperature	(见备注 1) (See note 1)	-40~+150	°C

备注 1: IPM 功率芯片最大额定结温为 150°C(@表面温度 T_c≤ 100°C)。然而,为了确保 IPM 运行安全,结温应限定于 T_{j(av)} ≤ 125°C (@表面温度 T_c ≤ 100°C)。

Remark 1: The maximum rated junction temperature of the IPM power chip is 150°C (@surface temperature T_C ≤ 100°C).

However, to ensure safe operation of the IPM, the junction temperature should be limited to T_{j(av)} ≤ 125°C (@surface temperature T_c ≤ 100°C).

控制部分 Control Part

记号 Mark	项目 Project	条件 Condition	额定值 Ratings	单位 Units
V _{DB}	上桥臂控制电源电压 Upper arm control supply voltage	应用于 UFB – U, VFB-V, WFB-W 之间 Applied between UFB-U, VFB-V, WFB-W	17.5	V
V _D	控制电源电压 Control supply voltage	应用于 VP1 – VNC 之间 Applied between VP1-VNC	17.5	V
V _{IN}	输入信号电压 Input signal voltage	应用于 UP, VP, WP, UN, VN, WN-VNC之间 Applied between UP, VP, WP, UN, VN, WN-VNC	-0.5~VD+0.5	V
V _{FO}	故障输出电压 Fault output voltage	应用于 FO – V _{NC} 之间 Applied between FO-VNC	-0.5~VD+0.5	V
I _{FO}	故障输出电流 Fault output current	FO 端子吸入电流值 FO terminal sink current value	1.5	mA
V _{sc}	电流检测端输入电压 Input voltage of current detection terminal	应用于 CIN – V _{NC} 之间 Applied between CIN-VNC	-0.5~VD+0.5	V

整个系统 Total System

记号 Mark	项目 Project	条件 Condition	额定值 Ratings	单位 Units
$V_{CC(Prot)}$	电源电压自己保护范围（短路） Power supply voltage self-protection range (short circuit)	$V_D = V_{DB} = 13.5 \sim 16.5V$ $T_j = 150^\circ C$, 无重复, 时间小于 2us $T_j = 150^\circ C$, no repetition, time is less than 2us	400	V
T_c	模块正常工作壳体温度 Module working temperature	$-20^\circ C \leq T_j \leq 150^\circ C$	-20 ~ +100	$^\circ C$
T_{stg}	贮存温度 Storage temperature	/	-40 ~ +125	$^\circ C$
Viso	绝缘耐压 Insulation withstand voltage	正弦波60Hz, AC 1分钟, 在插脚和散热片之间 Sine wave 60Hz, AC for 1 minute, between pin and heat sink	1500	Vrms



 图 4: 壳温 T_c 测试点

Fig 4: Case Temperature Measurement

热阻 Thermal Resistance

记号 Mark	项目 Project	条件 Condition	最小值 Min.	典型值 Typ.	最大值 Max.	单位 Unit
$R_{th(j-c)Q}$	结点到壳的热阻 Junction to case thermal resistance	单个 IGBT 元件 Single IGBT element	-	-	5.2	$^\circ C/W$
$R_{th(j-c)F}$		单个 FRD 元件 Single FRD element	-	-	5.9	$^\circ C/W$

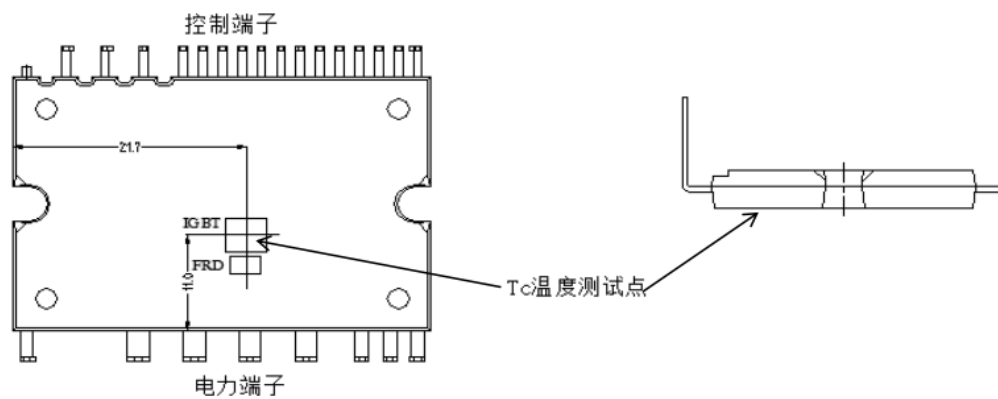

电气特性 (Tj=25°C, 除非特殊说明)

Electrical Characteristics (Tj=25°C, Unless Otherwise Specified)

逆变部分 Inverter Part

记号 Mark	项目 Project	条件 Condition	最小值 Min.	典型值 Typ.	最大值 Max.	单位 Unit
V _{CE(sat)}	集电极与发射极间饱和电压 Saturation voltage between collector and emitter	V _D = V _{DB} = 15V V _{IN} = 5V, I _C = 10A, T _J = 25°C	-	1.65	2.2	V
		V _D = V _{DB} = 15V V _{IN} = 5V, I _C = 10A, T _J = 125°C	-	1.85	-	V
V _F	FWD 正向导通电压 FWD forward voltage	V _{IN} = 0V, I _C = -10A, T _J = 25°C		1.65	2.2	V
t _{ON}	开关时间 (备注 2) Switching time (Note 2)	V _{CC} = 300V, V _D = V _{DB} = 15V, I _C = 10A V _{IN} = 0V-5V, 感性负载	-	650	-	ns
t _{c(ON)}			-	160	-	ns
t _{OFF}			-	670	-	ns
t _{c(OFF)}			-	60	-	ns
t _{rr}			-	130	-	ns
E _{on}	开通损耗 Turn-on loss	I _C = 10A, V _{CC} = 400V, V _{DB} = V _D = 15V, L = 500uH, T _J = 25°C		500	-	uJ
E _{off}	关断损耗 Turn-off loss			120	-	
I _{CES}	集电极到发射极漏电流 Collector to emitter leakage current	V _{CE} = V _{CES} T _J = 25°C	-	-	75	uA
		V _{CE} = V _{CES} T _J = 125°C	-	-	1	mA

备注 2: t_{ON} 和 t_{OFF} 包括驱动 IC 内部传输延迟时间。t_{c(ON)} 和 t_{c(OFF)} 是 IGBT 自身被内部给定门极驱动条件下的开关时间。详见图 5。

Remark 2: t_{ON} and t_{OFF} include the internal transmission delay time of the driver IC. t_{c(ON)} and t_{c(OFF)} are the switching times of the IGBT itself driven by the internally given gate. See Figure 5 for details.



图 5: 开关时间定义

Fig 5: Switching Time Definition

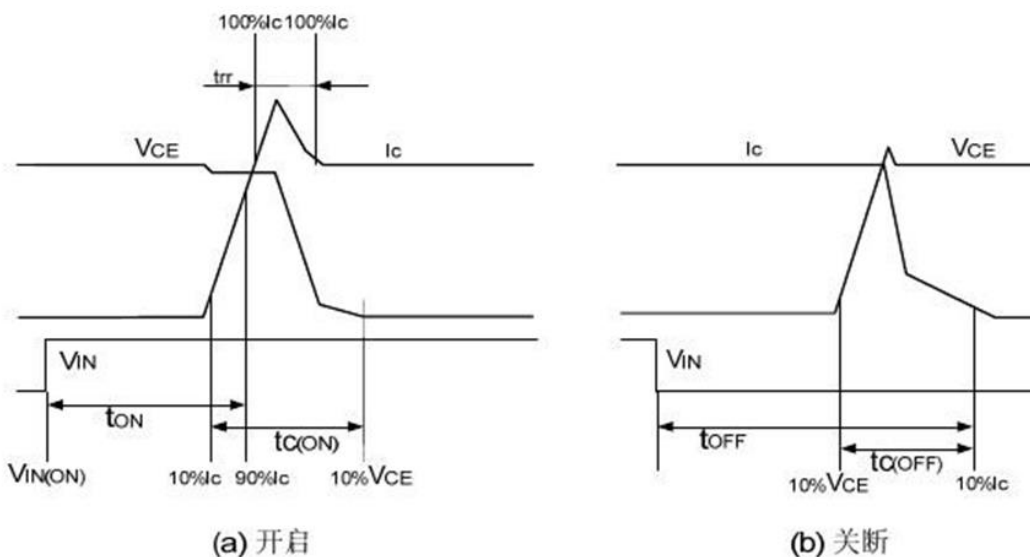

控制部分 Control Part

记号 Mark	项目 Project	条件 Condition		最小值 Min.	典型值 Typ.	最大值 Max.	单位 Unit
ID	V _D 静态电流 V _D Quiescent Current	V _D = 15V V _{IN} = 5V	VP1-VNC	-	0.7	1	mA
IDB	V _{DB} 静态电流 V _{DB} Quiescent Current	V _{DB} = 15V V _{IN} = 5V	UFB - U, VFB - V, WFB - W	-	0.7	1	mA
V _{FOH}	故障输出电压 Fault output voltage	V _{sc} = 0V, FO 脚通过 10K 电阻上拉至5V V _{sc} = 0V, FO pin is pulled up to 5V through 10K resistor		4.6	-	-	V
V _{FOL}		V _{sc} = 1V, I _{FO} = 1.5mA		-	-	0.5	V
V _{sc,TH+}	短路正向触发阈值 Short circuit forward trigger threshold	V _D = 15V		0.37	0.47	0.65	V
V _{sc,TH-}	短路负向触发阈值 Short circuit negative trigger threshold	V _D = 15V		0.2	0.4	-	V
UV _{DD}	电源欠压保护控制 Power undervoltage protection contro	触发电平 Trigger level		10.3	11.4	12.5	V
UV _{DR}		复位电平 Reset level		10.8	11.9	13.0	
UV _{DBD}		触发电平 Trigger level		9.0	10.0	11.0	
UV _{DBR}		复位电平 Reset level		10.0	11.0	12.0	
R _{on,FLT}	故障低有效阻抗 Fault low effective impedance	I = 1.5mA			50	90	ohm
T _{FO}	故障输出脉冲宽度 Fault output pulse width	-		40	-	-	uS
t _{FIL,IN}	输入信号滤过时间 (UP/VP/WP, UN/VN/WN) Input signal filtering time	V _{IN} = 0 V & 5 V		-	350	-	nS
t _{CINMIN}	CIN 输入信号滤过时间 CIN input signal filtering time	V _{IN} = 0 V or 5 V, V _{CIN} = 5 V		-	400	-	nS
V _{IN(ON)}	开启阈值电压 Turn on threshold voltage	应用于 UP, VP, WP, UN, VN, WN 和 VNC 之间 Applied between UP, VP, WP, UN, VN, WN and VNC		-	2.2	2.6	V
V _{IN(OFF)}	关断阈值电压 Turn-off threshold voltage			0.8	1.3	-	
V _{OT}	温度输出 (内部IC集成温度检测产品) Temperature output ((Internal IC integrated temperature detection products)	T _c = 90°C		2.63	2.77	2.91	V
		T _c = 25°C		0.88	1.13	1.39	
V _{OT}	温度输出 (内封NTC产品) Temperature output (products with NTC inside)	T _c = 90°C		1.53	1.59	1.65	V
		T _c = 25°C		4.15	4.17	4.19	
V _F	BSD 正向电压 BSD forward voltage	I _F = 10mA 包含电压 I _F = 10mA Including voltage		-	2.5	3.5	V
R _{BSD}	BSD限流电阻 BSD current limiting resistor			180	225	280	ohm



内部 NTC -热阻特性 Internal NTC-thermal resistance characteristics

记号 Mark	项目 Project	条件 Condition	最小值 Min.	典型值 Typ.	最大值 Max.	单位 Unit
RNTC	热敏电阻 Thermistor	TNTC = 25°C	97	100	103	Kohm
		TNTC = 125°C	3.25	3.46	3.69	Kohm
温度范围 temperature range			-40	-	+125	°C



图 6.1: VOT 输出电压曲线 (NTC 检测输出)

Figure 6.1: VOT output voltage curve (NTC detection output)

备注 3: IPM 的 VOT 输出特性曲线请参考图 6.1, 图 6.1 曲线是以 20K 上拉电阻测试结果。

Note3: refer to figure 5 for the VOT output characteristic curve of IPM. The curve in Figure 5 is the test result of 20K pull-up resistance.

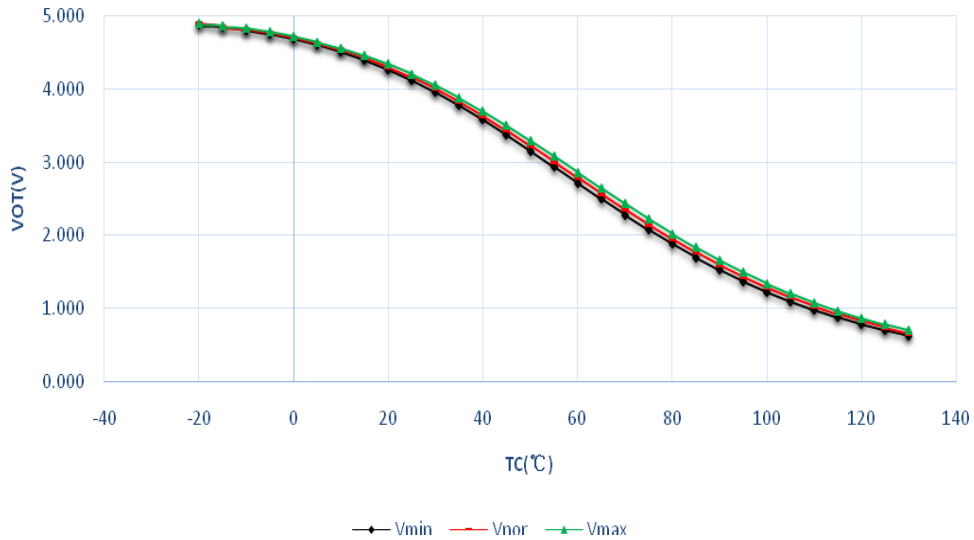
内部集成 VOT 温度输出特性 Internal integrated VOT temperature output



图 6.2: VOT 输出电压正温度系数曲线 (IC 内部检测输出)

Figure 6.2: VOT output voltage positive temperature coefficient curve (IC internal detection output)

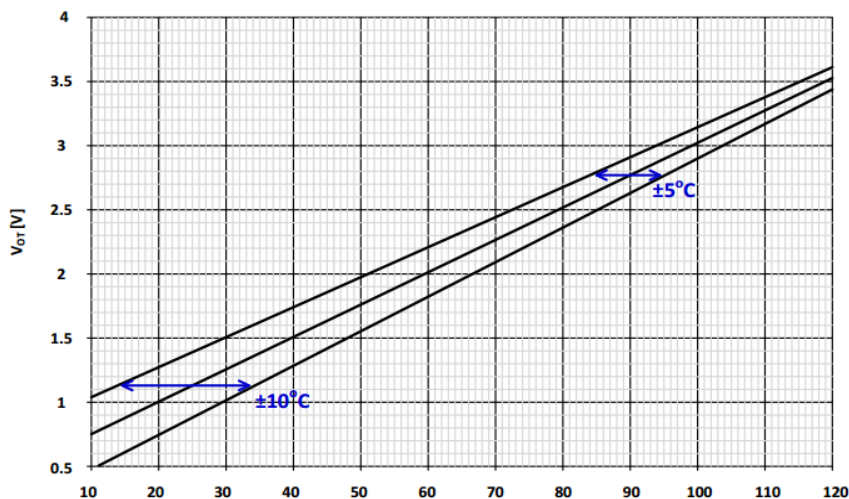

(1) 使用温度监测功能时，连接 $5k\Omega$ 的 VOT 引脚，省去内部 OTP 功能，如果使用内部超温停机功能，保持 VOT 引脚打开（无连接）。然而 VOT 也可操作，但精确度较低。

(1) When using the temperature monitoring function, connect the $5K\Omega$ VOT pin to omit the internal OTP function. If using the internal over temperature shutdown function, keep the VOT pin open (no connection). However, VOT can also be operated, but the accuracy is low.

(2) 在 3.3V 单片机等低压控制器上使用 VOT 时，VOT 输出可能超过控制电源电压温度上升过快时为 3.3V。如果系统使用低压控制器，建议插入夹钳控制器控制电源和 VOT 输出之间的二极管，用于防止过电压破坏。

(2) When using VOT on low-voltage controllers such as 3.3V single chip microcomputer, the VOT output may exceed the control power supply voltage. When the temperature rises too fast, it is 3.3V. If the system uses a low-voltage controller, it is recommended to insert the diode between the clamp controller control power supply and the VOT output to prevent overvoltage damage.

推荐工作条件 Recommended Operating Conditions

记号 Mark	项目 Project	条件 Condition	最小值 Min.	典型值 Typ.	最大值 Max.	单位 Unit
V _{cc}	电源电压 voltage	应用于 P – NU, NV, NW 之间 Applied between P – NU, NV, NW	0	300	400	V
V _D	控制电源电压 Control supply voltage	应用于 VP1 – VNC 之间 Applied between VP1-VNC	-	15	-	V
V _{DS}	上臂控制电源电压 Upper arm control power supply voltage	应用于 VUFB – U, VVFB – V, VWFB-W 之间 Applied between VUFB-U, VVFB-V, VWFB-W	-	15	-	V
t _{dead}	死区时间 Dead time	各桥臂输入对应, T _c ≤100℃ Corresponding to the input of each bridge arm, T _c ≤100℃	1	-	-	us
f _{PWM}	PWM 频率 PWM frequency	-20℃≤T _c ≤+100℃ -20℃≤T _j ≤+150℃	-	-	20	kHz
PWM	最小输入信号脉冲宽度 Minimum input signal pulse width	ON	1	-	-	us
		OFF	1	-	-	us
T _j	结温 Junction temperature	-	-20	-	125	℃



机械特性 Mechanical properties

项目 Project	条件 Condition	最小值 Min.	典型值 Typ.	最大值 Max.	单位 Unit
安装扭矩 Installation torque	螺丝钉尺寸: M3 Screw size: M3	-	0.69	-	N·m
设计平面度 Design flatness	见图 7 Figure 7	-50	-	+120	um
重量 weight	-	-	7	-	g



图 7: 平面度检测位置

Figure 7: Flatness detection position

应用指南 Application Guide

增强型输入滤波 Enhanced input filtering

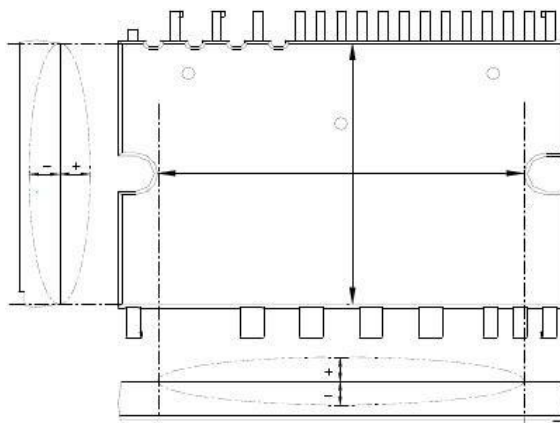
增强型滤波器能够改善 HVIC 内部模块的输入/输出脉冲的一致性及有助于滤除尖峰干扰信号和窄脉冲, 如下图 8 和图 9 是经典输入滤波器和增强型输入滤波器演示图。

The enhanced filter can improve the consistency of the input/output pulses of the internal modules of the HVIC and help to filter out the peak interference signals and narrow pulses, as shown in Figures 8 and 9 below are the classic input filter and enhanced input filter demonstration diagram.



图 8: 典型输入滤波

Figure 8: Typical input filtering Figure

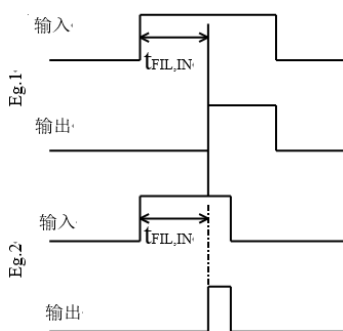

图 9: 增强型输入滤波

9: Enhanced input filtering

保护功能时序图 Timing diagram of protection function

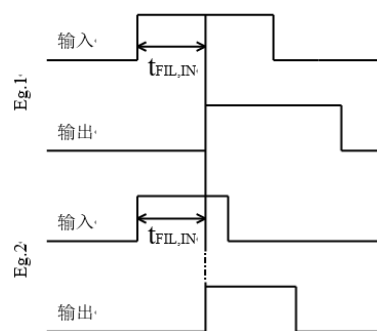

图 10: 直通保护

Figure 10: Pass-through protection

备注 4: HO 和 LO 为内部 HVIC 门极输出信号。

Note 4: HO and LO are internal HVIC gate output signals.

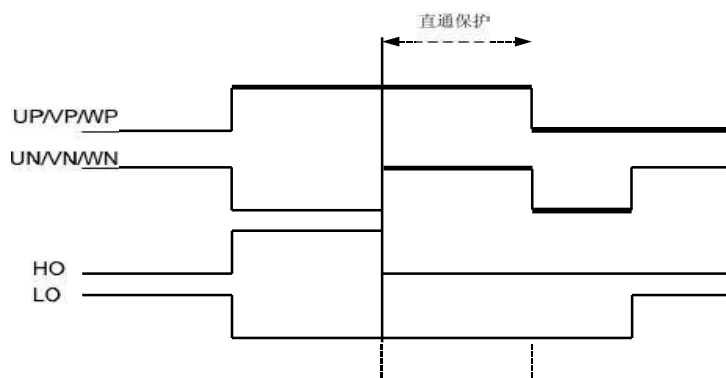

图 11: 欠压保护时序图(低侧)

Figure 11: Timing diagram of undervoltage protection (low side)

a1: 电源电压上升: 当该电压上升到欠压恢复点, 在下一个欠压信号被执行前该线路将启动运行。

a1: over supply voltage rise: When the voltage rises to the undervoltage recovery point, the line will start running before the next undervoltage signal is executed.

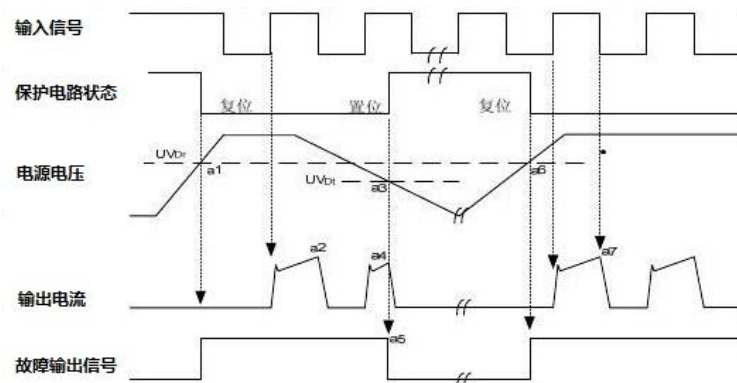
a2: 正常运行: IGBT 开启并加载电流。

a2: Normal operation: IGBT turns on and loads current.

a3: 欠压检测点(UVDt)。

a3: Undervoltage detection point (UVDt).

a4: 不管输入是什么信号, IGBT 都是关闭状态。

a4: No matter what signal is input, the IGBT is off.

a5: 故障输出开启。

a5: Fault output is on.

a6: 欠压恢复(UVDr)。

a6: Undervoltage recovery (UVDr).

a7: 正常运行: IGBT 导通并加载负载电流。

a7: Normal operation: IGBT is turned on and load current is loaded.



图 12: 欠压保护时序图 (高侧)

Figure 12: Timing diagram of undervoltage protection (high side)

b1: 电源电压上升: 当该电压上升到欠压恢复点, 在下一个欠压信号被执行前该线路将启动运行。

b1: Power supply voltage rise: When the voltage rises to the undervoltage recovery point, the line will start running before the next undervoltage signal is executed.

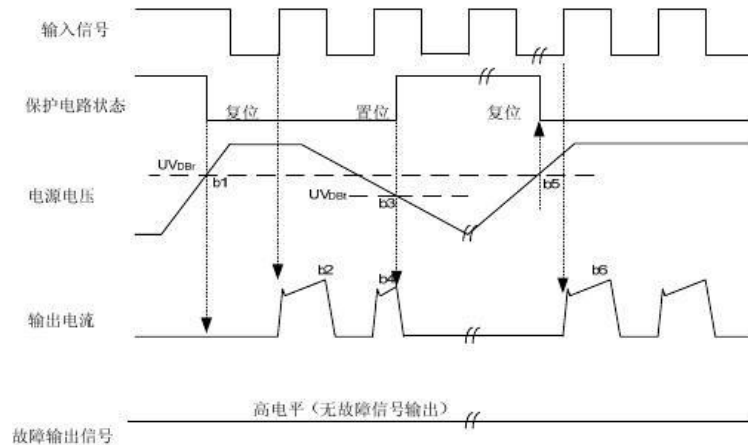
b2: 正常运行: IGBT 导通并加载负载电流。

b2: Normal operation: IGBT is turned on and load current is applied.

b3: 欠压检测 (UVDBt)。

b3: Undervoltage detection (UVDBt).

b4: 不管输入是什么信号, IGBT 都是关闭状态。

b4: No matter what signal is input, IGBT is off.

b5: 欠压恢复(UVDBr)。

b5: Undervoltage recovery (UVDBr).

b6: 正常运行: IGBT 导通并加载负载电流。

b6: Normal operation: IGBT is turned on and load current is applied.



图 13: 短路电流保护时序图 (只适合于低侧)
(通过外部分流电阻连接)

Figure 13: Timing diagram of short-circuit current protection (only suitable for low side)
(Connected via external shunt resistor)

c1: 正常运行: IGBT 导通载流。

c1: Normal operation: IGBT conducting current.

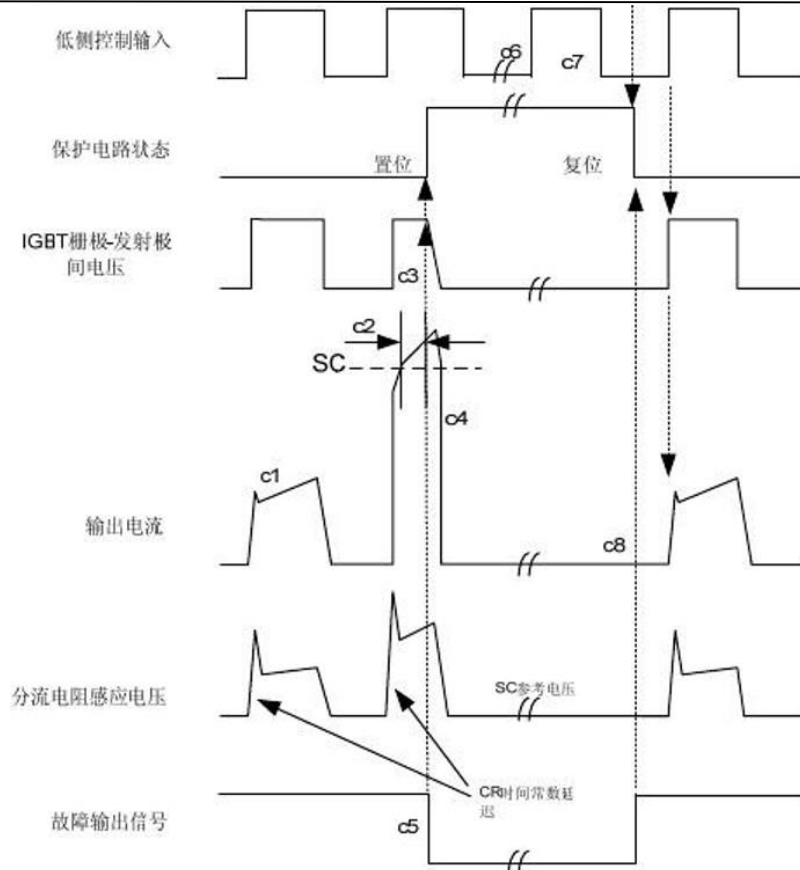
c2: 短路电流检测 (CIN 触发器)。

c2: Short-circuit current detection (CIN trigger).

c3: IGBT 门极被强制关断。

c3: IGBT gate is forcibly turned off. c4: IGBT is turned off.

c4: IGBT 关断。

c4: IGBT is turned off.

c5: 故障输出定时器开始运行: 故障输出信号的脉冲宽度是由外部电容 CFO 设定。

c5: The fault output timer starts to run: The pulse width of the fault output signal is set by the external capacitor CFO.

c6: 输入“L”: IGBT 关闭。

c6: Input "L": IGBT is off.

c7: 输入“H”: IGBT 开通, 但是故障信号作用期间, IGBT 不导通。

c7: Input "H": The IGBT is turned on, but the IGBT is not turned on during the fault signal.

c8: IGBT 关断。

c8: IGBT is turned off.

输入/输出接口电路 Input/output interface circuit



图 14: 推荐的 MCU 输入输出接口电路

Figure 14: Recommended MCU input and output interface circuit

备注 5: 由于 PWM 的控制方式和实际应用电路的阻抗及线路板的阻抗, RC 去耦可能会有变化。

Note 5: Due to the PWM control method and the impedance of the actual application circuit and the impedance of the circuit board, RC decoupling may change.

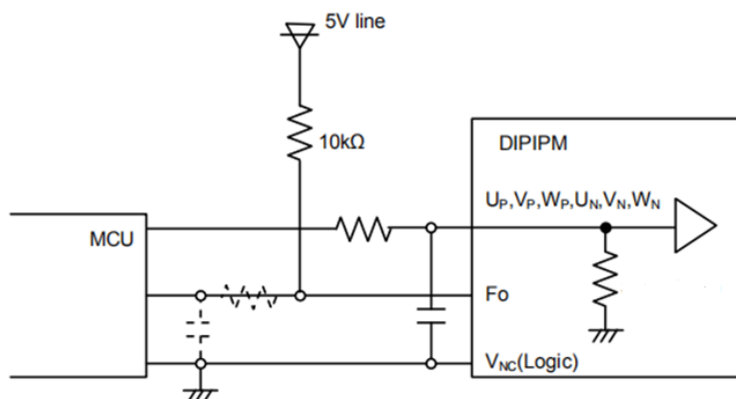
备注 6: 逻辑输入要和标准的 CMOS 或 LSTTL 输出相匹配。

Note 6: The logic input must match the standard CMOS or LSTTL output.

分流电阻接线 Shunt resistor wiring



图 15: 旁路电阻接线注意事项

Figure 15: Precautions for bypass resistance wiring

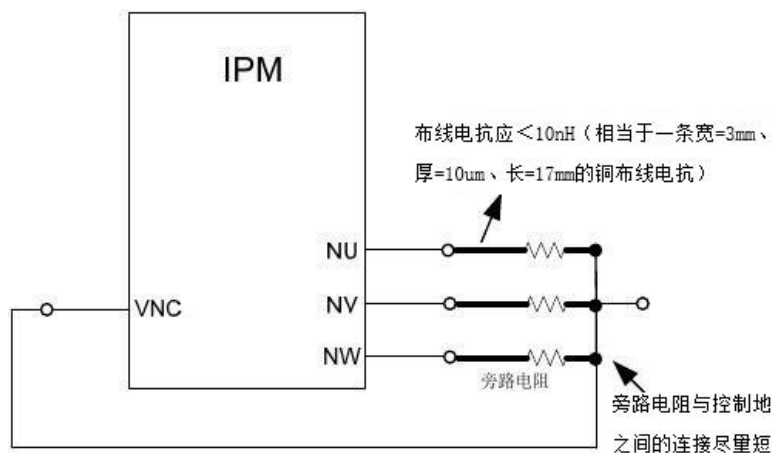

图 16: 典型应用电路

Figure 16: Typical application circuit

备注 7: 输入驱动高有效; IC 内部集成有一个 $5k\Omega$ (典型值)下拉电阻; 为防止发生误动作, 输入布线应尽可能短; 当用 RC 去耦线路时, 须确保输入信号达到开启和关断阈值电压范围。

Remark 7: The input drive is highly effective; a $5k\Omega$ (typical value) pull-down resistor is integrated inside the IC; in order to prevent malfunctions, the input wiring should be as short as possible; when using RC decoupling lines, make sure that the input signal reaches on and off Threshold voltage range.

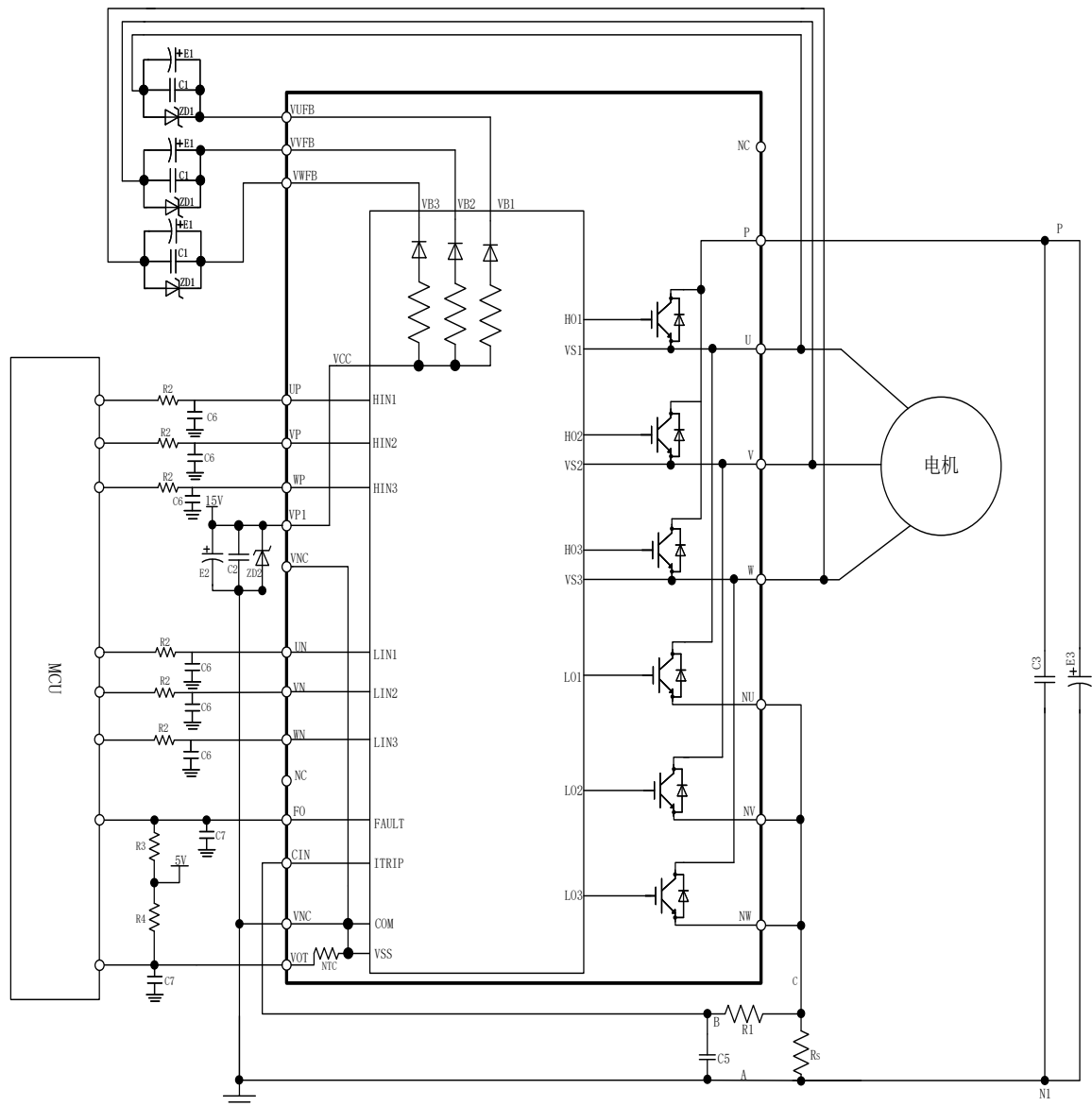
备注 8: 由于模块内置了专用 HVIC, 其控制端子可与 CPU 端子直接相连, 而不需要任何光耦或变压器等隔离电路。



Remark 8: Since the module has a built-in dedicated HVIC, its control terminal can be directly connected to the CPU terminal without any isolation circuit such as optocoupler or transformer.

备注 9: 自举电路负极应直接连接到 U、V、W 的端。

Remark 9: The negative pole of the bootstrap circuit should be directly connected to the U, V, W terminals.

备注 10: FO 是漏极开路型, 其信号线应通过一个约 10kΩ 的上拉电阻上拉到+5V/3.3V 电源。

Remark 10: FO is an open-drain type, and its signal line should be pulled up to a +5V/3.3V power supply through a pull-up resistor of about 10kΩ.

备注 11: 为防止误保护, A、B、C 连线应尽可能短。

Note 11: To prevent false protection, the A, B, and C wiring should be as short as possible.

备注 12: 保护线路 R1、C5 的时间常数建议选取在 1~2μS。关断时间可能随着布线的不同而多少有些变化。建议 R1、C5 选择小容差, 温度补偿类型。

Remark 12: The time constant of protection lines R1 and C5 is recommended to be 1~2μS. The turn-off time may vary somewhat depending on the wiring. It is recommended that R1 and C5 choose small tolerance and temperature compensation type.

备注 13: 所有电容的位置尽可能的靠近 IPM。

Remark 13: Position all capacitors as close to IPM as possible.

备注 14: 为了防止噪声干扰, 储能电容与 P&N1 之间的引线应尽可能的短, 推荐在 P&N1 端子之间加约 0.1~0.22μF 的 MLCC 低频滤波电容。

Note 14: In order to prevent noise interference, the lead between the storage capacitor and P&N1 should be as short as possible. It is recommended to add about 0.1~0.22μF of MLCC low-frequency filter capacitor between P&N1 terminals.

备注 15: 两个 VNC 端 (9&16 脚) 在 IPM 内部已连接在一起, 外部任一 VNC 端子连接到 GND, 另一端允许开路。

Remark 15: The two VNC terminals (pins 9 & 16) are connected together inside the IPM, any external VNC terminal is connected to GND, and the other terminal is allowed to open.

备注 16: 如果控制地通过 PCB 走线被连接到功率地, 控制信号可能会受到功率地的起伏的影响, 推荐使用单点连接。

Remark 16: If the control ground is connected to the power ground through PCB traces, the control signal may be affected by the fluctuation of the power ground. It is recommended to use a single point connection.



DIP25-FP (管脚长度: 常规)

单位: mm



图 17.1: 封装尺寸示意图

Figure 17.1: Schematic diagram of package size

DIP25-FP (管脚长度: 短脚)

单位: mm

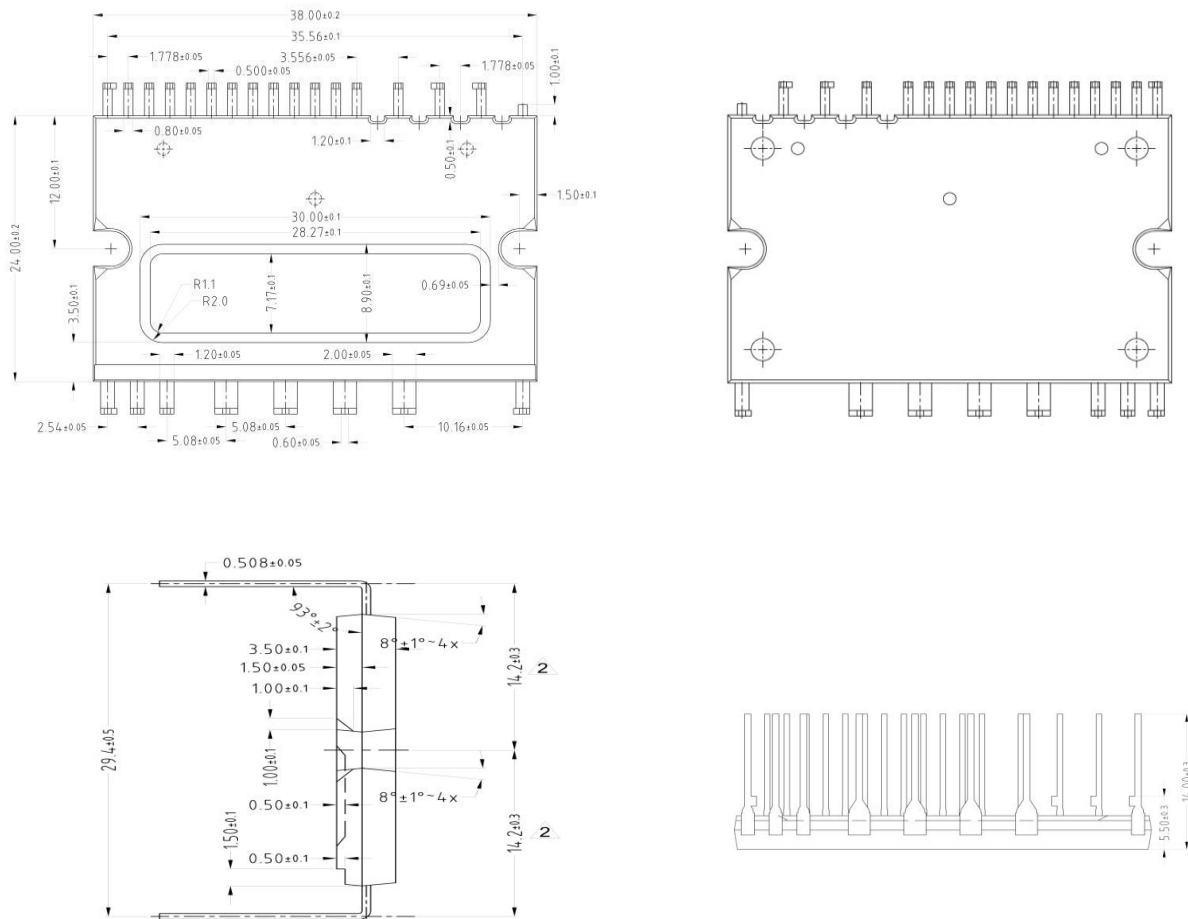

图 17.2: 封装尺寸示意图

Figure 17.2: Schematic diagram of package size

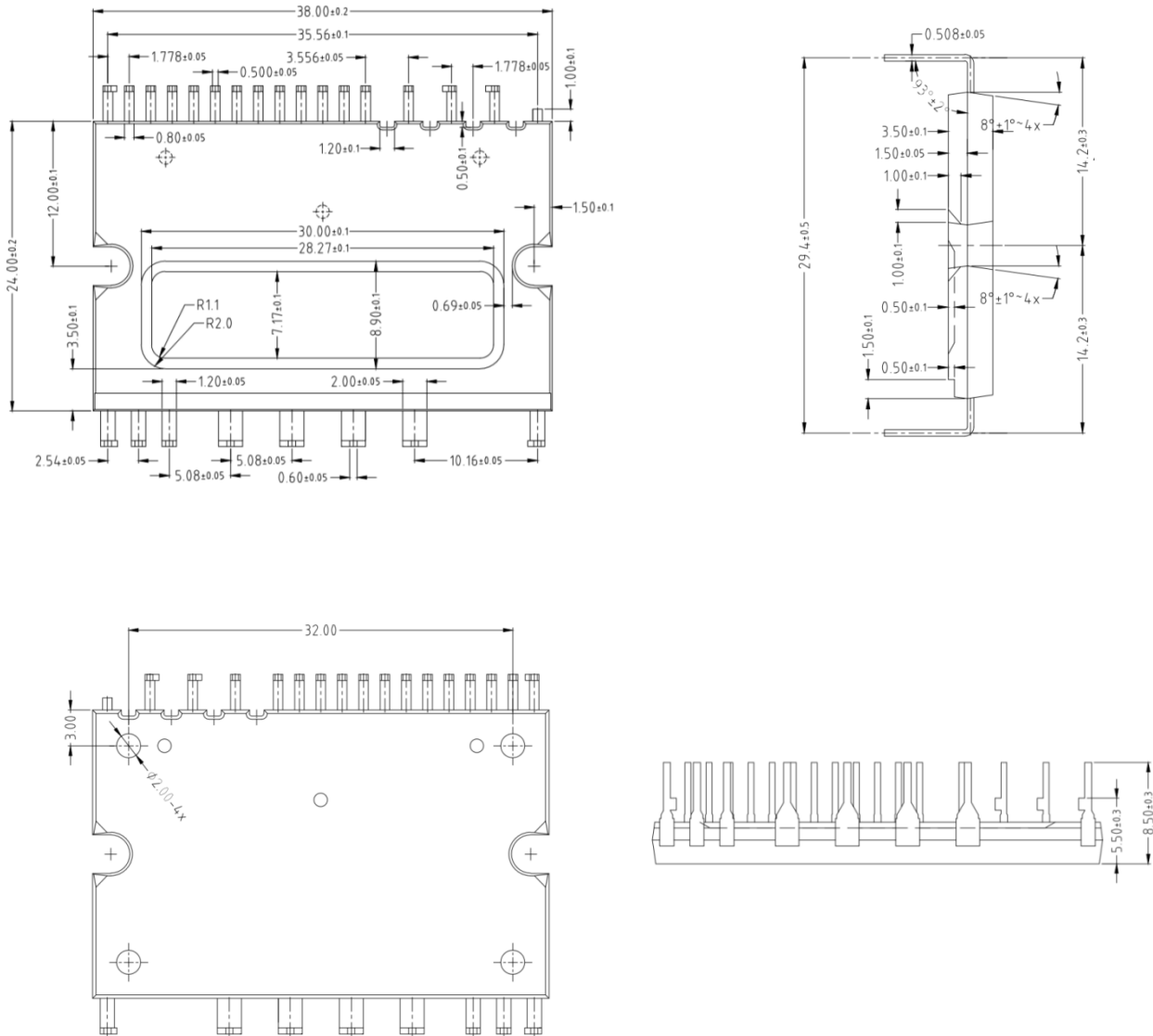

注意事项

1. 吉林华微电子股份有限公司的产品销售分为直销和销售代理，无论哪种方式，订货时请与公司核实。
2. 购买时请认清公司商标，如有疑问请与公司本部联系。
3. 在电路设计时请不要超过器件的绝对最大额定值，否则会影响整机的可靠性。
4. 本说明书如有版本变更不另外告知。

NOTE

1. Jilin Sino-microelectronics co., Ltd sales its product either through direct sales or sales agent , thus, for customers, when ordering , please check with our company.
2. We strongly recommend customers check carefully on the trademark when buying our product, if there is any question, please don't be hesitate to contact us.
3. Please do not exceed the absolute maximum ratings of the device when circuit designing.
4. Jilin Sino-microelectronics co., Ltd reserves the right to make changes in this. specification sheet and is subject to change without prior notice.

联系方式

吉林华微电子股份有限公司

公司地址：吉林省吉林市深圳街 99 号

邮编：132013

总机：86-432-64678411

传真：86-432-64665812

网址：www.hwdz.com.cn

CONTACT

JILIN SINO-MICROELECTRONICS CO., LTD.

ADD: No.99 Shenzhen Street, Jilin City, Jilin Province, China.

Post Code: 132013

Tel: 86-432-64678411

Fax: 86-432-64665812

Web Site: www.hwdz.com.cn